

**3M** Science.  
Applied to Life.™

**LifeASSURE™ PFS Series  
PTFE Filters**



## LifeASSURE™ PFS Series PTFE filters

LifeASSURE™ PFS series PTFE filters offer the ultimate in microorganism retention for air and gas streams while providing superior air flow capacity.

- 3M Purification Inc.'s LifeASSURE PFS series PTFE filters with flow enhanced construction allow use of smaller, more economical air filter assemblies compared to competitive air filters.
- LifeASSURE PFS series PTFE filters provide absolute retention based on liquid bacteria challenge and aerosol bacteriophage challenge.
- LifeASSURE PFS series PTFE filters are available in a wide range of cartridge and capsule configurations to provide the most economical solution to air, gas and aggressive liquid filtration applications.

## Cartridge & capsule configurations to meet any process requirement

LifeASSURE PFS series PTFE filters are available in 5" through 40" cartridges, 2.5" and 5" Mini Cartridges and 2.5", 5", 10", 20" and 30" capsules. With the exceptionally high flow rates, smaller and more economical assemblies can provide the same air flow as larger, more costly competitive PTFE filters.

## Features & benefits

---

### Flow enhancing layer construction

Higher air flow for fermenter aeration and smaller, more economical vent filter assemblies

---

### Liquid validation of *B. diminuta* retention

Reliable sterilizing performance in wet or dry conditions

---

### Hydrophobic PTFE membrane

Membrane will not become blocked with moisture

---

### 21 CFR Materials of Construction, USP Biological Safety Test, Validation Guide and Drug Master File Listing

Eases validation and regulatory submissions



# LifeASSURE™ PFS Series PTFE filter applications

LifeASSURE™ PFS series PTFE filters are optimized for applications requiring sterilization of air, gas or aggressive solvents and chemicals. The hydrophobic PTFE filter membrane prevents wetting with aqueous liquids or moisture that can block free air flow. Some applications, however, may require filtration of aggressive fluids such as acids or bases. Depending on compatibility, LifeASSURE PFS series PTFE filters can be used to provide sterile filtration of these fluids by prewetting the membrane with a low surface tension fluid such as alcohol. A list of LifeASSURE PFS series PTFE filter applications includes:

- Sterile venting of process tanks
- Sterile filtration of process air and aseptic filling lines
- Sterile venting of lyophilizers
- Sterile venting of autoclaves
- Sterile air filtration on blow, fill, and seal machines
- Sterilizing filtration of fermentation inlet and exhaust air
- Sterile filtration of aggressive liquids

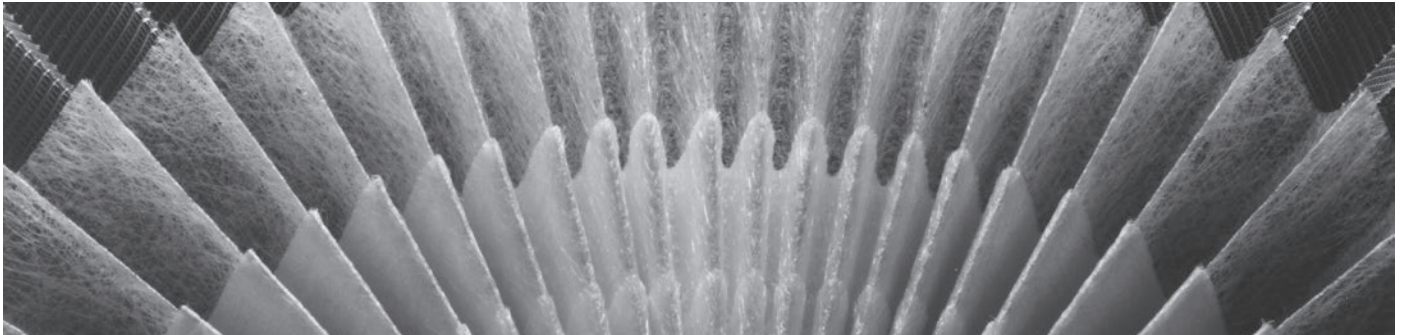
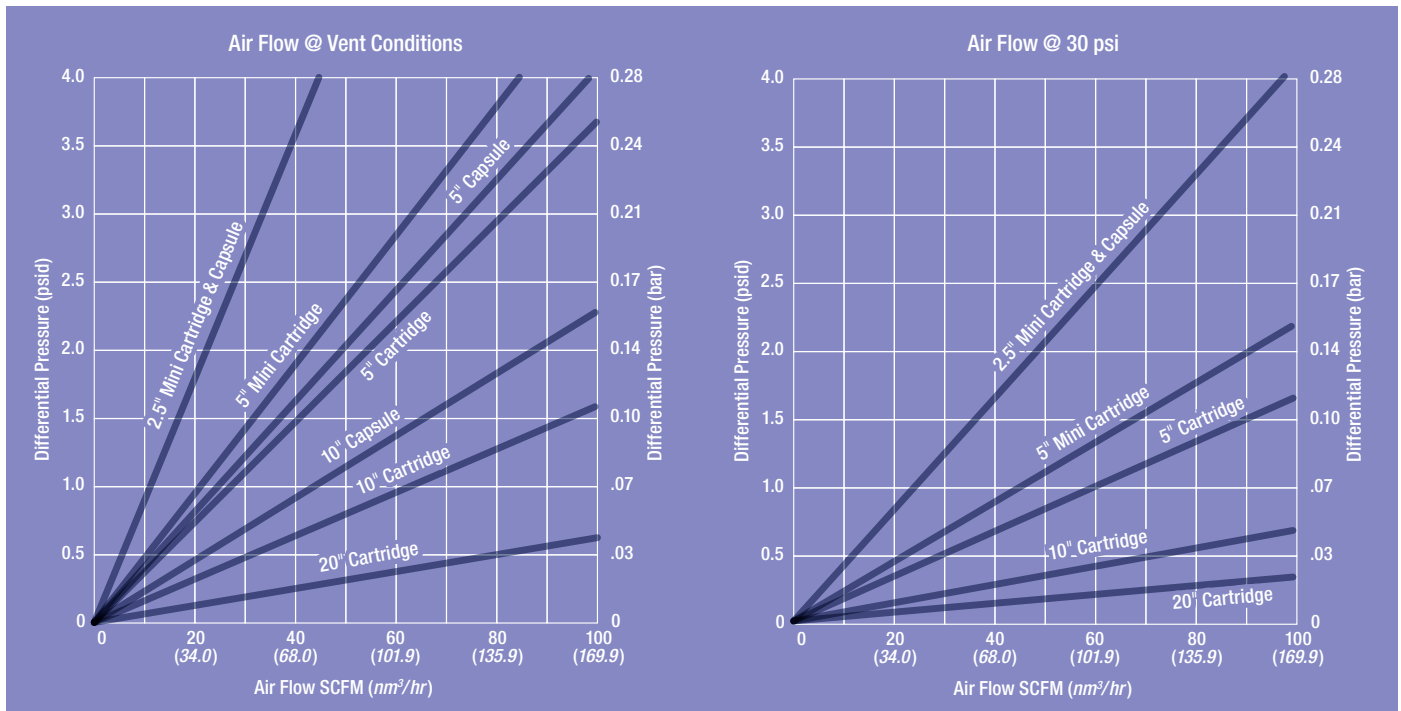

Photo 1. LifeASSURE™ PFS series PTFE filter detail.

LifeASSURE PFS series PTFE filters were designed to provide exceptionally high flow rates with low differential pressures (Figure 1). LifeASSURE PFS series PTFE filters are available in a range of cartridge and capsule filter configurations to meet any process requirement. Shown in Figure 1 are flow curves for filter assemblies at atmospheric (vent) and compressed air conditions. For details of sizing vent and compressed air assemblies, please ask for 3M Purification automated sizing program assistance.

Figure 1. LifeASSURE PFS series PTFE filter air flow vs. differential pressure\*



\* Cartridge airflow values with housing pressure loss subtracted (excluding capsules).

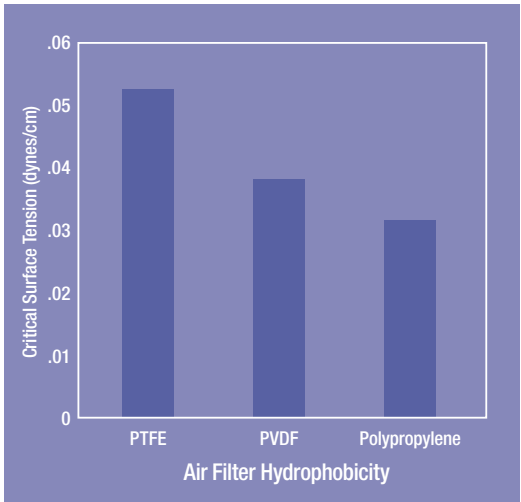

**Graph 1. Comparative hydrophobicity.**

## The LifeASSURE™ PFS Series PTFE Filter advantage

LifeASSURE™ PFS series PTFE filters combine high flow with a liquid validated, bacteria retentive, hydrophobic PTFE filter membrane. Filter structural components are polypropylene, optimized for long on-stream air service. The most important characteristics for a sterilizing grade air filter include:

### Validated PTFE membrane

LifeASSURE PFS series PTFE filters are validated by liquid bacteria challenge for complete retention. Liquid bacteria challenge represents the most severe test of filter performance and provides the highest assurance level of reliable sterilizing performance. In addition, LifeASSURE PFS series PTFE filters have demonstrated complete aerosol retention of the bacteriophage X-174. For complete details, request the LifeASSURE PFS series Validation Guide (70-0201-8843-2).

### Hydrophobicity

Free air flow with little resistance requires that the filter membrane not wet with water or moisture. Membrane wetting can result in filter pore blockage, which in turn prevents free air flow and can cause filter failure. In order to prevent pore blockage, an extremely hydrophobic PTFE membrane is used which prevents wetting with water or moisture. Graph 1 shows the relative hydrophobicity of filter media used in air filters. As can be seen, PTFE offers the highest level of hydrophobicity ensuring optimum air flow service.

### High air flow

Efficient performance requires maximum air flow at minimum pressure drop. LifeASSURE PFS series PTFE air filters are constructed to achieve higher air flow vs. pressure drop compared to competitive air filters. This 3M Purification development involves the use of specially designed PTFE filter membrane and polypropylene flow enhancing layers. This construction is applied to LifeASSURE PFS series PTFE filters. Photo 3 shows how each layer is positioned within the filters.

**Photo 3. LifeASSURE™ PFS series PTFE filter construction.**

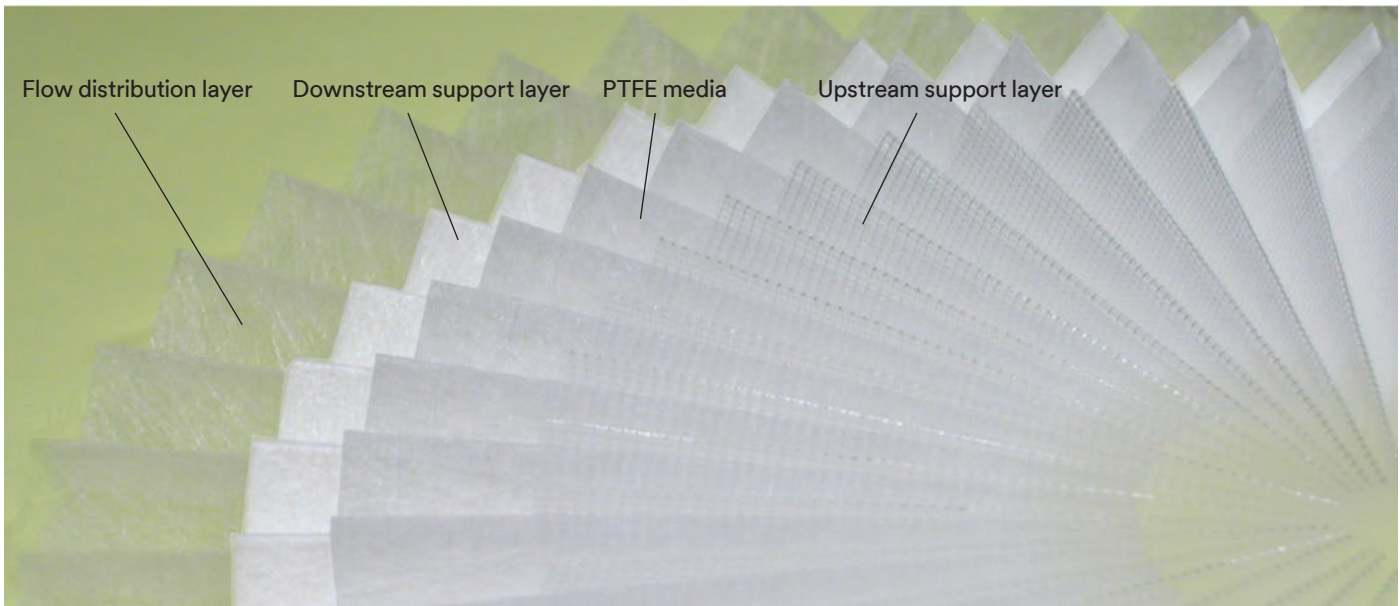

## Superior flow rate performance

LifeASSURE™ PFS series PTFE filters offer outstanding flow rate performance at low differential pressures. Whether used for tank venting, lyophilizer or autoclave vacuum breaking, blow, fill, seal machines or fermentation air sterilization, filter flow rate is a critical parameter. Using the design enhancements described, LifeASSURE PFS series PTFE filters provide maximum flow performance. Graph 2 presents the comparison of LifeASSURE PFS series PTFE filter performance to competitive air filters.

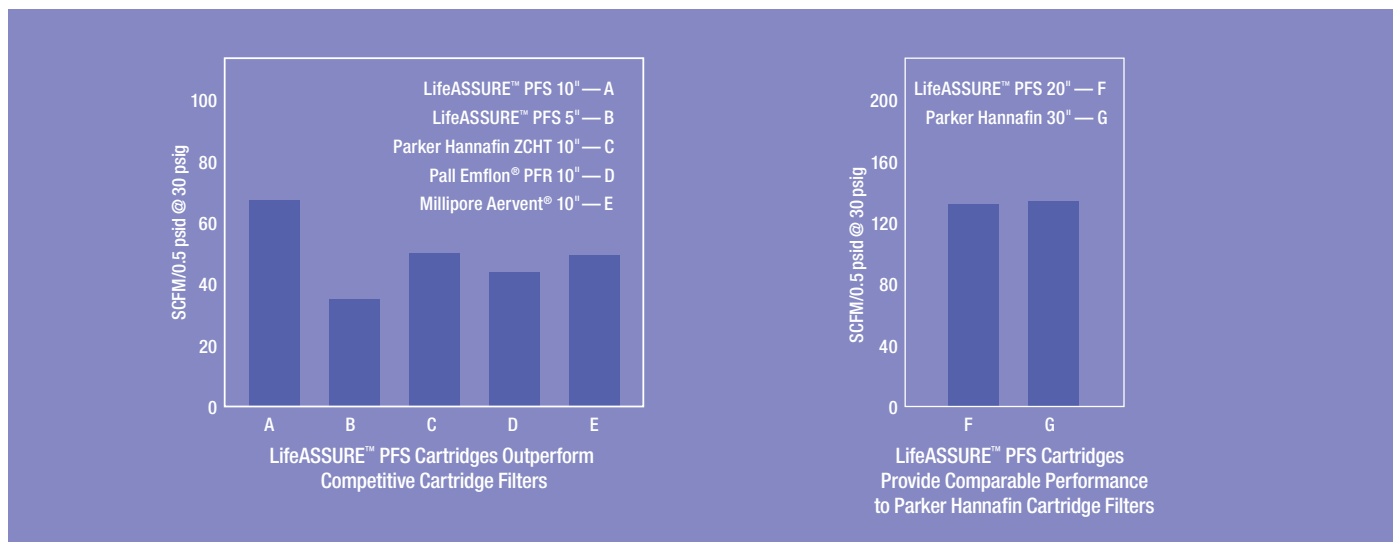

Graph 2. Air flow rate comparisons.

## Reliable microorganism retention performance

LifeASSURE PFS series PTFE filters are validated for sterilizing performance using a liquid bacteria (*B. diminuta*) challenge test method. Liquid bacteria retention testing is the most critical test of sterilizing filter performance and provides the user with the utmost assurance that critical product or fermentation broth will be protected from contamination. In addition to demonstrating sterilizing performance in liquid, LifeASSURE PFS series PTFE filters were tested for complete bacteriophage retention using aerosol challenge test methods. Aerosol retention performance provides users that LifeASSURE PFS series PTFE filters will provide reliable air and gas sterilization. Aerosol challenge testing was performed using X-174 bacteriophage which are small organisms that infect bacteria cells and can ruin bacteria fermentation processes. Complete retention of bacteriophage was observed as shown in Table 1. For complete details request the 3M LifeASSURE PFS Series Validation Guide (70-0201-8843-2).

Table 1. LifeASSURE PFS series PTFE filter retention performance.

Test Method	Test Organism	Test Result
Liquid Bacteria Challenge	<i>B. diminuta</i>	Sterile
Aerosol Virus Test	X-174 Bacteriophage	0 Plaque Forming Units

## Scientific Applications Support Services (SASS)

3M Purification Inc.'s years of experience are synonymous with quality, performance and high-level technical support. The cornerstone of 3M Purification's philosophy is service to customers, not only in product quality and prompt delivery, but also in validation assistance, applications support and in the sharing of scientific information. 3M Purification's Scientific Applications Support Services (SASS) group works closely with customers to solve difficult separations problems and to recommend the most economical and efficient filter system. SASS Specialists are skilled in performing on-site testing and relating test results to full-scale manufacturing operations.



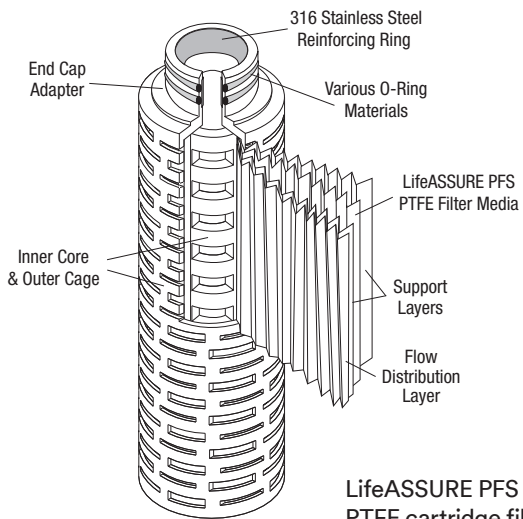

Standard Cartridge

LifeASSURE PFS series PTFE cartridge filters are available in 5" through 40" with a variety of end fittings and O-ring options to meet hardware and process requirements.

3M Purification 2.5" and 5" LifeASSURE PFS series PTFE mini cartridges can be installed in existing Pall Sealkleen™ housings or 3M Purification mini cartridge housing (70-0201-8886-1).

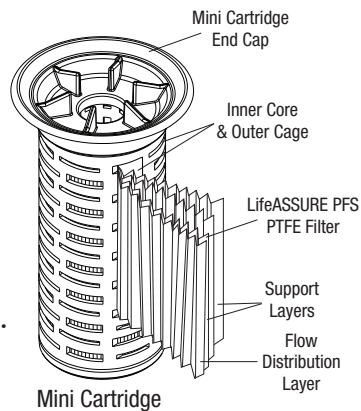

Mini Cartridge

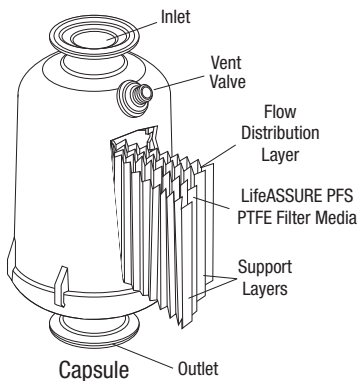

LifeASSURE PFS series PTFE capsule filters are available in 2.5", 5", 10", 20" and 30" configurations. Capsule filters may be autoclave sterilized and offer a convenient, easy to use format for air sterilization. As with LifeASSURE PFS series PTFE cartridge filters, the capsule filters have been specially designed to provide optimum air flow. Capsules are not recommended for continuous compressed gas service.

## Quality & reliability

LifeASSURE™ PFS series PTFE filters are manufactured within an ISO 9001:2008 registered quality system and are 100% diffusion flow tested prior to shipment. All materials of construction are 21 CFR listed and filter components have been tested in accordance with United States Pharmacopoeia (USP) Class VI Biological Safety. All LifeASSURE PFS series PTFE filters are shipped with a Certificate of Quality affirming compliance with rigid manufacturing quality specifications. Supporting Drug Master File (DMF) documentation is on file with the United States Food and Drug Administration (FDA). A complete LifeASSURE PFS series Validation Guide (70-0201-8843-2) is available upon request.

## Integrity testing

LifeASSURE PFS series PTFE filters can be easily and automatically tested to verify filter integrity pre and post use using the CUNOCheck™ 2 integrity test instrument. Filters can be tested using diffusive flow, pressure hold, bubble point or water intrusion test (WIT) methods. Refer to 3M Purification publication (70-0201-8804-4) — Integrity Testing LifeASSURE PFS Series PTFE filters.



## Quality management & ISO standards

3M Purification has maintained its leadership in fluid purification and filtration by continually providing superior products and technical support. 3M Purification Inc. filtration systems are designed and manufactured to the most stringent industry standards to provide the reliability of 3M Purification Inc. systems that our customers have come to expect.

3M Purification has established a global quality management program which encompasses all facets of its operations. An essential part of the program is the creation of multi-function teams whose combined expertise is devoted to continuous improvement of processes, procedures and quality systems. In addition, the system has the active support and participation of senior management. 3M Purification Inc. is fully committed to the tenets of the quality management program and provides a support system for the quality process. The majority of 3M Purification Inc. manufacturing plants are ISO 9001:2008 registered. At 3M Purification Inc., quality is defined by the never-ending pursuit for continuous improvement in products, services, and personnel.

# Operating parameters and specifications

Filter Configuration	Cartridge	Mini Cartridge		Capsule**				
	5" to 40"	2.5"	5"	2.5"	5"	10"	20"	30"
Filter Rating	0.2 µm							
Materials of Construction								
Membrane	PTFE							
Membrane Support Layer	Polypropylene							
Inner core, outer cage, end cap adapters, and adapters	Polypropylene							
Adapter Reinforcing Ring	Stainless Steel	NA						
Filtration Surface Area: ft <sup>2</sup> (m <sup>2</sup> )	11 (1.02)*	1.8 (0.17)	3.7 (0.34)	2.8 (0.26)	5.5 (0.51)	11 (1.02)	22 (2.04)	33 (3.07)
Maximum Differential Pressure								
Forward Pressure	80 psid (5.5 bar) @ 77 °F (25 °C) 25 psid (1.7 bar) @ 176 °F (80 °C)			75 psid (5.2 bar) @ 104 °F (40 °C)				
Reverse Pressure	65 psid (4.5 bar) @ 77 °F (25 °C)			65 psid (4.5 bar) @ 77 °F (25 °C)				
Maximum Operating Temperature	176 °F (80 °C)			104 °F (40 °C)				
Integrity Test Parameters - Forward Flow Test - @ 16 psig (1.1 bar)***								
25%/75% (v/v) TBA/Water @ 20 °C and 1 atm: cc/min.	≤ 8.7 *	≤ 1.4	≤ 2.9	≤ 2.2	≤ 4.4	≤ 8.7	≤ 17.4	≤ 26.1
60%/40% (v/v) IPA/Water @ 25 °C and 1 atm: cc/min.	≤ 35.5*	≤ 5.8	≤ 11.9	≤ 9.0	≤ 17.8	≤ 35.5	≤ 71.0	≤ 106.5
70%/30% (v/v) IPA/Water @ 25 °C and 1 atm: cc/min.	≤ 54.0*	≤ 8.8	≤ 18.2	≤ 13.7	≤ 27.0	≤ 54.0	≤ 108.0	≤ 162.0
Minimum Bubble Point: psig (bar)****	16 (1.1)							
Water Intrusion Test — Maximum Allowable Flow at 40 psig (2.76 bar) @ 20 °C and 1 atm: cc/min.	0.59	0.10	0.20	0.15	0.30	0.59	1.18	1.77
Autoclave Conditions:	Up to 259 °F (126 °C)							
<i>In situ</i> Steam Conditions:	Up to 293 °F (145 °C)			Do not <i>in situ</i> steam				

\* per 10" element

\*\* not for continuous compressed gas service.

\*\*\* NOTE: Wetting fluid should be maintained within +/- 2% v/v concentration and +/- 2 °C temperature.

\*\*\*\* Wet with 25%/75% (v/v) TBA/Water, 60%/40% (v/v) IPA/Water, or 70%/30% (v/v) IPA/Water.

## 3M Purification Inc. Filter Housings

A complete line of sanitary design, stainless steel filter housings is available for LifeASSURE™ PFS series PTFE cartridge filters. Options are available for heat traced (electrical and steam jacketed) housings where condensate is a concern. Specialized configurations and housing designs are also available for high flow, fermentation air filtration applications.

Housing Model	Mini ZMS	ZMS	ZWB	ZVS	Mini Cartridge Housing		
Basic Part #/ Cartridge Capacity	For 5" Cartridge	For 10", 20", 30" and 40" cartridges			For 2.5" Mini Cartridges	For 5" Mini Cartridges	
	70236 / 1	70628-01	70612 / 3		70627-01	7023502 / 1	7023501 / 1
		70628-02	70614 / 5		70627-02		
		70628-03	70616 / 8		70627-03		
		70628-04	70626 / 12		70627-04		
Housing Style	T-line Sanitary type connection			Sanitary type in-line			
Equivalent Cartridge Lengths	5"	10", 20", 30" and 40"			2.5"	5"	
Materials of Construction	316L Stainless Steel						
Pressure & Temperature Ratings	150 psi (10 bar) @ 212 °F (100 °C)	150 psi (10 bar) @ 212 °F (100 °C)	150 psi (10 bar) @ 200 °F (90 °C)	150 psi (10 bar) @ 212 °F (100 °C)	150 psi (10 bar) @ 300 °F (149 °C)	150 psi (10 bar) @ 300 °F (149 °C)	
Literature #	70-0201-8887-9	70-0201-8883-8	70-0201-8884-6	70-0201-8883-8	70-0201-8886-1		

# LifeASSURE™ PFS Series PTFE Filter ordering guide

## Cartridges

Grade Designation	Configuration	Height (Inches)	End Modification	O-ring Material
PFSO20	A	01 - 10	B - 226 O-ring & spear	A - Silicone
		02 - 20	C - 222 O-ring & spear	B - Fluorocarbon
		03 - 30	F - 222 O-ring & flat cap	C - EPR
		04 - 40	J - 226 O-ring & flat cap	D - Nitrile
		50 - 5		K - PTFE Encapsulated Fluorocarbon

## Mini Cartridges

Grade Designation	Configuration	Height (Inches)	End Modification	Package Quantity
PFSO20	R	01 - 2.5 02 - 5	AN	06 - 6-pack

## Capsules

Grade Designation	Configuration	Height (Inches)	End Modification	Vent O-ring Material	Package Quantity
PFSO20	J	01 - 10	A - Sanitary fitting	A - Silicone	01 - 1-pack
		02 - 20		B - Fluorocarbon	
		03 - 30		C - EPR	
		25 - 2.5			
		50 - 5			

### Important Notice

The information described in this literature is accurate to the best of our knowledge. A variety of factors, however, can affect the performance of the Product(s) in a particular application, some of which are uniquely within your knowledge and control. **INFORMATION IS SUPPLIED UPON THE CONDITION THAT THE PERSONS RECEIVING THE SAME WILL MAKE THEIR OWN DETERMINATION AS TO ITS SUITABILITY FOR THEIR USE. IN NO EVENT WILL 3M PURIFICATION INC. BE RESPONSIBLE FOR DAMAGES OF ANY NATURE WHATSOEVER RESULTING FROM THE USE OF OR RELIANCE UPON INFORMATION.**

It is your responsibility to determine if additional testing or information is required and if this product is fit for a particular purpose and suitable in your specific application.

**3M PURIFICATION INC. MAKES NO REPRESENTATIONS OR WARRANTIES, EITHER EXPRESS OR IMPLIED INCLUDING WITHOUT LIMITATION ANY WARRANTIES OF MERCHANTABILITY, FITNESS FOR A PARTICULAR PURPOSE OR OF ANY OTHER NATURE HEREUNDER WITH RESPECT TO INFORMATION OR THE PRODUCT TO WHICH INFORMATION REFERS.**

### Limitation of Liability

3M Purification Inc. will not be liable for any loss or damage arising from the use of the Product(s), whether direct, indirect, special, incidental, or consequential, regardless of the legal theory asserted, including warranty, contract, negligence or strict liability. Some states do not allow the exclusion or limitation of incidental or consequential damages, so the above limitation may not apply to you.

Your Local Distributor:



3M Purification Inc.  
400 Research Parkway  
Meriden, CT 06450, U.S.A.  
Tel (800) 243-6894  
(203) 237-5541  
Fax (203) 630-4530  
[www.3M.com/purification](http://www.3M.com/purification)

© 2022 3M. All rights reserved. 3M and the other marks shown are marks and/or registered marks. LifeASSURE and CUNOCheck are trademarks of 3M Company. Unauthorized use prohibited. 3M marks used under license in Canada. All other marks are property of their respective owners.  
70-0201-8715-2 REV 0622