



Atmospheric Control Module

SAFE, AUTOMATIC
PRESSURIZED CONTAINMENT



PROTECTING PEOPLE AND THEIR ENVIRONMENTS FROM EXPOSURE

Handling today's higher-potency active pharmaceutical ingredients (HPAPIs) presents ever-increasing regulatory concerns — especially within manufacturing-area isolators and lab areas, and for flexible GMP chambers where airflow, temperature, humidity and pressure differentials exist from room to room.

The Atmospheric Control Module's precise fan speed provides accurately controlled negative air pressure to ensure proper flow into flexible-wall isolators, while reducing the risk of worker exposure. ArmorFlex Isolator systems can also be operated with positive air pressure for applications requiring sterility, as well as facilitate relative-humidity control.

Atmospheric Control Module can operate adjacent to the contained compartment or in a separate room, and the fan is rated 250 m³/h — a much higher fan capacity than many competitors' systems.

ArmorFlex® is a trademark of ILC Dover.

ILC Dover's Atmospheric Control Module is available in both single-fan/single-vent and dual-fan/double-vent configurations. Both offer the same high level of containment performance, and both can help to create an ideal isolation environment for fine-tuned powder weighing and processing, solubility testing, milling, granulation and more.

The single-fan/single-vent system satisfies most applications.

The dual-fan/double-vent system provides superior performance when application requirements include recirculation to reduce N₂ or compressed-air consumption, or when weak HVAC makes single-pass room-air use undesirable.





Norges Flow Controller

Filter Oil Pressure

FE Dil. Pressure



AIRFLOW

PORTABLE AND COMPACT

FULLY AUTOMATED CONTROL
WITH WARNING ALARMS

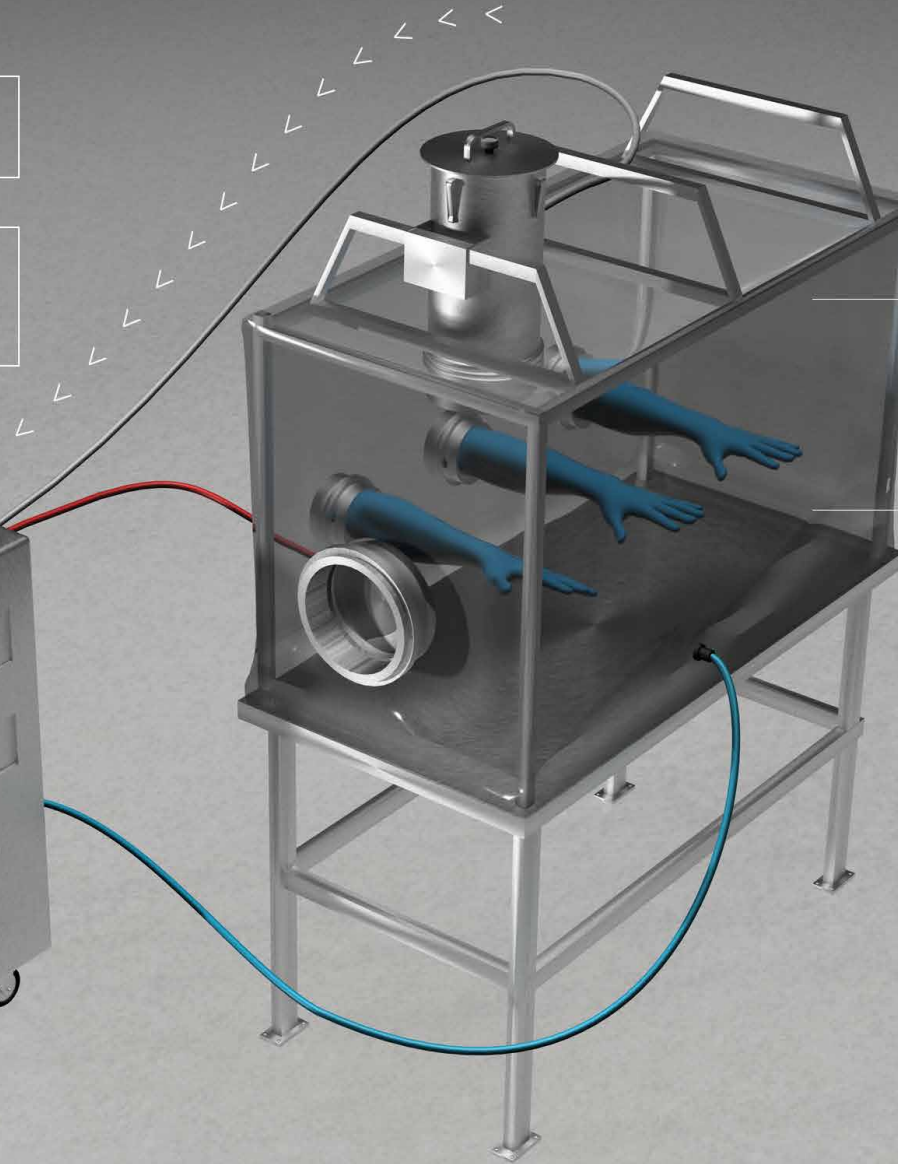

 = GAS FEED LINE FROM ARMORFLEX PRESSURE CONTROL MODULE TO ENCLOSURE

 = PRESSURE SENSOR CONNECTION BETWEEN ARMORFLEX PRESSURE CONTROL MODULE AND ENCLOSURE

HIGH CONTAINMENT
ISOLATOR SYSTEM
WITH VACUUM CONTROL
AND BREACH RESPONSE

AIR OR NITROGEN
ENVIRONMENT

ARMORFLEX® ATMOSPHERIC CONTROL MODULE: 7 ADVANTAGES, ONE SMART SOLUTION

1 *AUTOMATED SAFETY*

The Atmospheric Control Module allows for easy and confident handling of expensive and dangerous powders. It detects even the most minute pressure change, immediately adjusting the gradient back to the set point. This means the product will remain contained, with no manual adjustments of the vent speed. Operator distraction is no longer your biggest worry.

2 *OPTIMUM ENCLOSURE OPERATION*

Atmospheric Control Module units can introduce and maintain supply gas or compressed air at a set point of -15 Pa, so enclosures remain ergonomic and easy to work with. Competitors' exhaust-only systems can create uneven or unsustainable pressures of -25 Pa to -50 Pa.

3 *AUTOMATIC N₂ INERTING*

The Atmospheric Control Module can be used with N₂ for compounds that are oxygen sensitive or explosive. It can use fresh N₂ or recirculate it to save costs.

It can also control humidity and reduce the chance of explosions.

4 SENSITIVITY

This system allows for sensitive powder weighing because it is able to cancel the influence of the pressure on the scale.

5 ADAPTABLE, EASY TO MODIFY

Atmospheric Control Module can be connected to both existing and new flexible isolators throughout your facility. In addition, the frames can be retrofitted to accommodate push-push 130 m³/hr contaminant filters, permitting upgrade for future needs. They can also be modified for exhaust and supply enclosure connections.

6 READY FOR EXPLOSIVE ENVIRONMENTS

All Atmospheric Control Modules can be specified with a choice of 480V/3-phase, 230V/single-phase or — if required — 120V/single-phase power supply to meet ATEX directive 2014/34/EU.





7 ERGONOMIC BENEFIT

Operator movement is not restricted like it is with a hard-wall isolator or even a laminar flow hood with a sash. The flexible isolator is supported by stretch cords that allow a generous range of motion.

The typical problem of “reach” in an isolator is minimized. The flexible wall moves as the operator extends his or her reach into the isolator, making tasks easier, with less stress. This benefit can also facilitate a design with more depth to meet process requirements.

The flexible isolator allows for a wide range of operator heights, so multiple users can comfortably use the same equipment. With the stretch-cord system, the glove sleeves adjust to the operator size.

The unique glove and gauntlet design combines typical glove materials with lightweight ArmorFlex® film gauntlets or glove sleeves. The operator can move easily and comfortably with this design.

ArmorFlex film used for the flexible isolators has high strength and eliminates the risk of failure even when operators are moving to the extreme positions in the isolator.

ArmorFlex® is a trademark of ILC Dover.

TALK WITH OUR EXPERTS

At ILC Dover, we look forward to collaborating with you to develop systems tailored to your exact needs. To speak with one of our experts, simply call **+1.800.631.9567** or visit **www.ilcdover.com**.



BEYOND BOUNDARIES™

ILC Dover is a world-leader in the innovative design and production of engineered flexible protective solutions, for pharmaceutical and biopharmaceutical, flood protection, personal protection, bulk packaging, and aerospace industries. Our customers will attest to our relentless dedication to high value products, advanced technology, and responsive service, as our visionary solutions have improved efficiency while safeguarding people, product, and infrastructure in hazardous conditions through flexible protective solutions since 1947.



One Moonwalker Road
Frederica, DE 19946 USA

+1.302.335.3911

+1.800.631.9567

customer_service@ilcdover.com

www.ilcdover.com

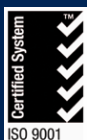

MKT-0136 Rev. C